

The 18SWS1000 is a high-power 18-inch subwoofer, designed for use in professional applications. It is specifically designed to reproduce the range of 36 to 150 Hz in a 6 to 7 cubic foot (170-200 liter) vented box.

The 18SWS1000 is capable of handling up to 1000 watts RMS (NBR or 2,000 watts continuous program power).

A bumped and undercut T-yoke assures a minimum of magnetic rectification (off-centering) and a compatible maximum displacement (Xlim). The extended pole ensure a correct magnetic flux distribution and improve the thermal dissipation. The magnet circuit was optimized by finite element software. Special attention was given to the driver's behavior under mechanical overload conditions, meaning that all but the most severe abuse will be tolerated - without failure.

The 18SWS1000 employ a 4" (100mm) diameter 4-layer aluminum round wire voice-coil. This is wound on a fiberglass-composite former, twice the thickness of typical formers, to drive the moving assembly with great rigidity.

The non-pressed-long-fiber-pulp cone has the necessary mass and stiffness to withstand the tremendous accelerating forces required, and is precisely centered by two counter-balancing, distortion canceling, polyester-cotton-fiber spiders.

A reinforced aluminum frame is highly effective in withstanding mechanical shocks and vibration. It also acts as a heat-sink for the motor, without removing energy from the loudspeakers intended magnetic gap. The aluminum frame includes six vents that allow air exchange between the spider and the top-plate. This helps to reduce top-plate temperature, in turn cooling the voice-coil. The magnetic-circuit also employs a multi-cooling system (patent pending) consisting of a large diameter center hole, surrounded by six smaller holes that forces cool air across the voice-coil. These features insure an extremely efficient heat transfer from voice-coil to surroundings, resulting in very high thermal power handling.

SPECIFICATIONS

Nominal diameter	460 (18)	mm (in)
Nominal impedance	8	
Minimum impedance @ 93 Hz	7.0	
Power handling		
Peak	4,000	W
Continuous Music ¹	2,000	W
NBR ²	1000	W
AES ³	800	W
Sensitivity (2.83V @ 1m) averaged from 50 to 150 Hz	96	dB SPL
Power compression @ 0 dB (nom. power)	3.9	dB
Power compression @ -3 dB (nom. power)/2	3.1	dB
Power compression @ -10 dB (nom. power)/10	1.6	dB
Frequency response @ -10 dB	36 to 2,000	Hz

¹ Power handling specifications refer to normal speech and/or music program material, reproduced by an amplifier producing no more than 5% distortion. Power is calculated as true RMS voltage squared divided by the nominal impedance of the loudspeaker.

² NBR Standard (10,303 Brazilian Standard).

³ AES Standard (60 - 600 Hz).

THIELE-SMALL PARAMETERS

Fs	36	Hz
Vas	214 (7.55)	l (ft ³)
Qts	0.50	
Qes	0.51	
Qms	1.4	
o (half space)	1.88%	
Sd	0.1194 (185.07)	m ² (in ²)
Vd (Sd x Xmax)	1,611.9 (98.36)	cm ³ (in ³)
Xmax (max. excursion (peak) with 10% distortion)	6.75 (0.27)	mm (in)
Xlim (max. excursion (peak) before physical damage)	21.0 (0.83)	mm (in)

Atmospheric conditions at TS parameter measurements:

Temperature	24 (75)	°C (°F)
Atmospheric pressure	1,015	mb
Humidity	52	%

Thiele-Small parameters are measured after a 2-hour power test using half AES power. A variation of ±15% is allowed.

ADDITIONAL PARAMETERS

L	21.7	Tm
Flux density	0.66	T
Voice coil diameter	100 (4)	mm (in)
Voice coil winding length	48.0 (157.5)	m (ft)
Wire temperature coefficient of resistance (25)	0.00380	1/°C
Maximum voice coil operating temperature	320 (613)	°C (°F)
vc (max. voice coil operating temp./max. power)	0.40 (0.76)	°C/W (°F/W)
Hvc (voice coil winding depth)	25.0 (0.98)	mm (in)
Hag (air gap height)	11.5 (0.44)	mm (in)
Re	5.8	
Mms	183 (0.403)	g (lb)
Cms	110	µm/N
Rms	2.94	kg/s

NON-LINEAR PARAMETERS

Le @ Fs (voice coil inductance @ Fs)	8.55	mH
Le @ 1 kHz (voice coil inductance @ 1 kHz)	4.86	mH
Le @ 20 kHz (voice coil inductance @ 20 kHz)	2.92	mH
Red @ Fs	0.47	
Red @ 1 kHz	11.51	
Red @ 20 kHz	204.27	
Krm	2.6	
Kxm	21.5	mH
Erm	0.96	
Exm	0.83	



ADDITIONAL INFORMATION

Magnet material	Barium ferrite
Magnet weight	3,440 (120) g (oz)
Magnet diameter x depth	220 x 24 (8.66 x 0.95) mm (in)
Magnetic assembly weight	9,350 (20.61) g (lb)
Frame material	Aluminum
Frame finish	Black epoxy
Voice coil material	Aluminum
Voice coil former material	Fiberglass
Cone material	Non pressed long fiber pulp
Volume displaced by woofer	8.6 (0.304) l (ft ³)
Net weight	11,300 (24.91) g (lb)
Gross weight	12,950 (28.55) g (lb)
Carton dimensions (W x D x H)	48 x 48 x 25 (18.9 x 18.9 x 9.9) cm (in)

MOUNTING INFORMATION

Number of bolt-holes	8
Bolt-hole diameter	7.0 (0.27) mm (in)
Bolt-circle diameter	439 (17.28) mm (in)
Baffle cutout diameter (front mount)	422 (16.61) mm (in)
Baffle cutout diameter (rear mount)	412 (16.22) mm (in)
Connectors	Silver-plated push terminals
Polarity	Positive voltage applied to the positive terminal (red) gives forward cone motion
Minimum clearance between the back of the magnetic assembly and the enclosure wall	75 (3) mm (in)

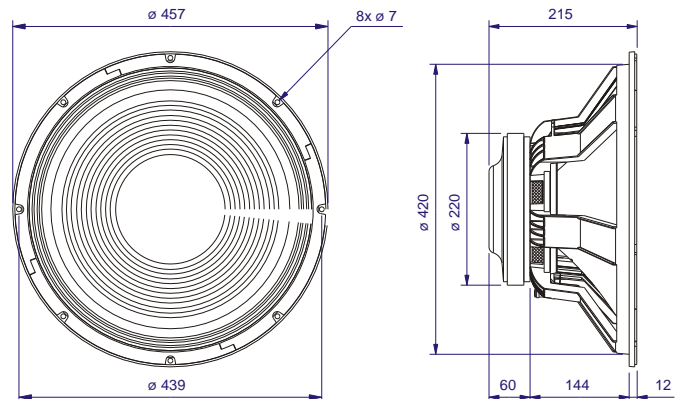

Dimensions in mm.

RESPONSE CURVES (0° AND 45°) IN A TEST ENCLOSURE IN ANECHOIC CHAMBER, 1 W / 1 m

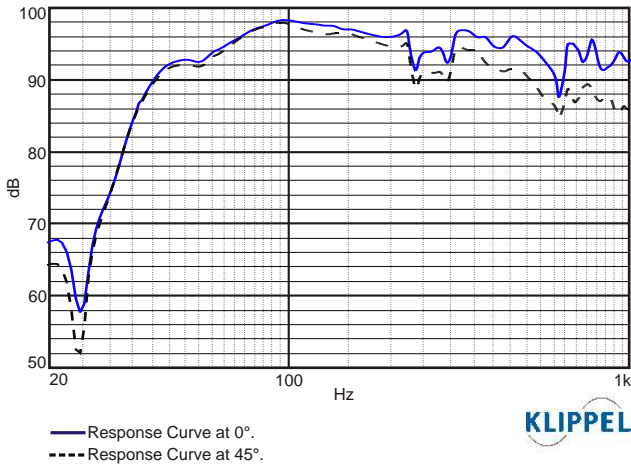

Response curves measured in anechoic chamber with the subwoofer installed in a test enclosure, 1 W / 1 m.

POLAR RESPONSE CURVES

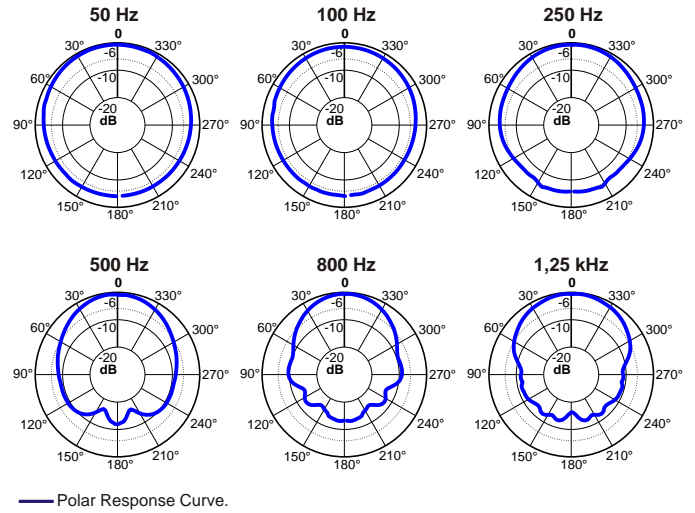

IMPEDANCE AND PHASE CURVES, MEASURED IN FREE-AIR

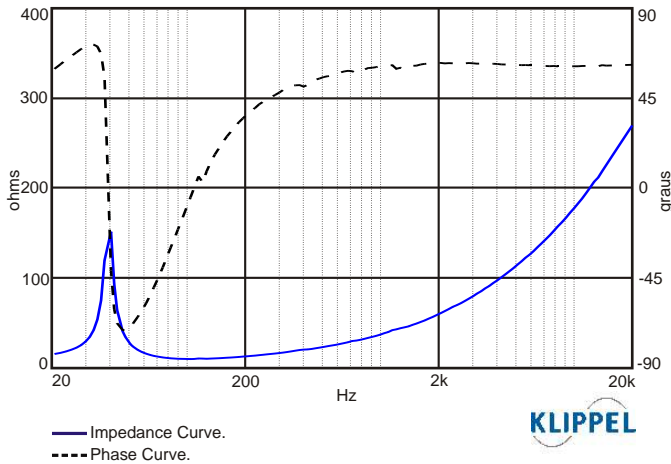

HARMONIC DISTORTION CURVES MEASURED AT 10% AES INPUT POWER IN A TEST ENCLOSURE INSIDE AN ANECHOIC CHAMBER, 1 m

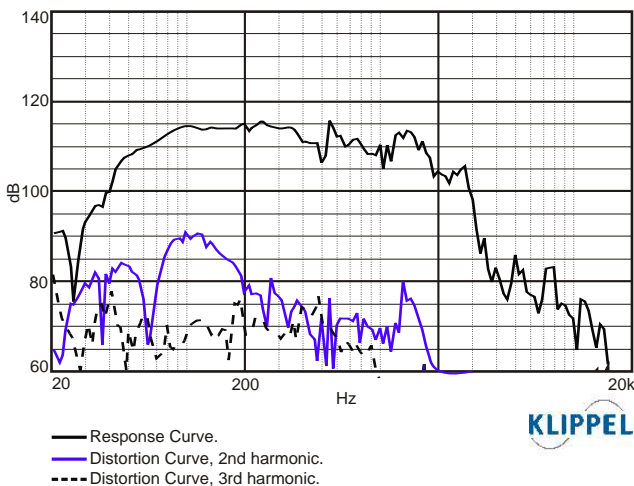

TEST ENCLOSURE

191-liter volume with 3 ducts ø 6" by 7.87" length.

HOW TO CHOOSE THE RIGHT AMPLIFIER

The power amplifier must be able to supply twice the RMS driver power. This 3 dB headroom is necessary to handle the peaks that are common to musical programs. When the amplifier clips those peaks, high distortion arises and this may damage the transducer due to excessive heat. The use of compressors is a good practice to reduce music dynamics to safe levels.

FINDING VOICE COIL TEMPERATURE

It is very important to avoid maximum voice coil temperature. Since moving coil resistance (R_e) varies with temperature according to a well known law, we can calculate the temperature inside the voice coil by measuring the voice coil DC resistance:

$$T_B = T_A + \frac{R_B}{R_A} - 1 \quad T_A = 25 + \frac{1}{25}$$

T_A, T_B = voice coil temperatures in °C.

R_A, R_B = voice coil resistances at temperatures T_A and T_B , respectively.

$_{25}$ = voice coil wire temperature coefficient at 25 °C.

POWER COMPRESSION

Voice coil resistance rises with temperature, which leads to efficiency reduction. Therefore, if after doubling the applied electric power to the driver we get a 2 dB rise in SPL instead of the expected 3 dB, we can say that power compression equals 1 dB. An efficient cooling system to dissipate voice coil heat is very important to reduce power compression.

NON-LINEAR VOICE COIL PARAMETERS

Due to its close coupling with the magnetic assembly, the voice coil in electrodynamic loudspeakers is a very non-linear circuit. Using the non-linear modeling parameters K_{rm}, K_{xm}, E_{rm} and E_{xm} from an empirical model, we can calculate voice coil impedance with good accuracy.

SUGGESTED PROJECTS

HB1805A1 HB1805B1 HB1805C1 VB1805A1 PAS1G1 PAS2G1
PAS3G1 VB18P1

For additional project suggestions, please access our website.